

# SOLEADO ARKO

ART. 654102070

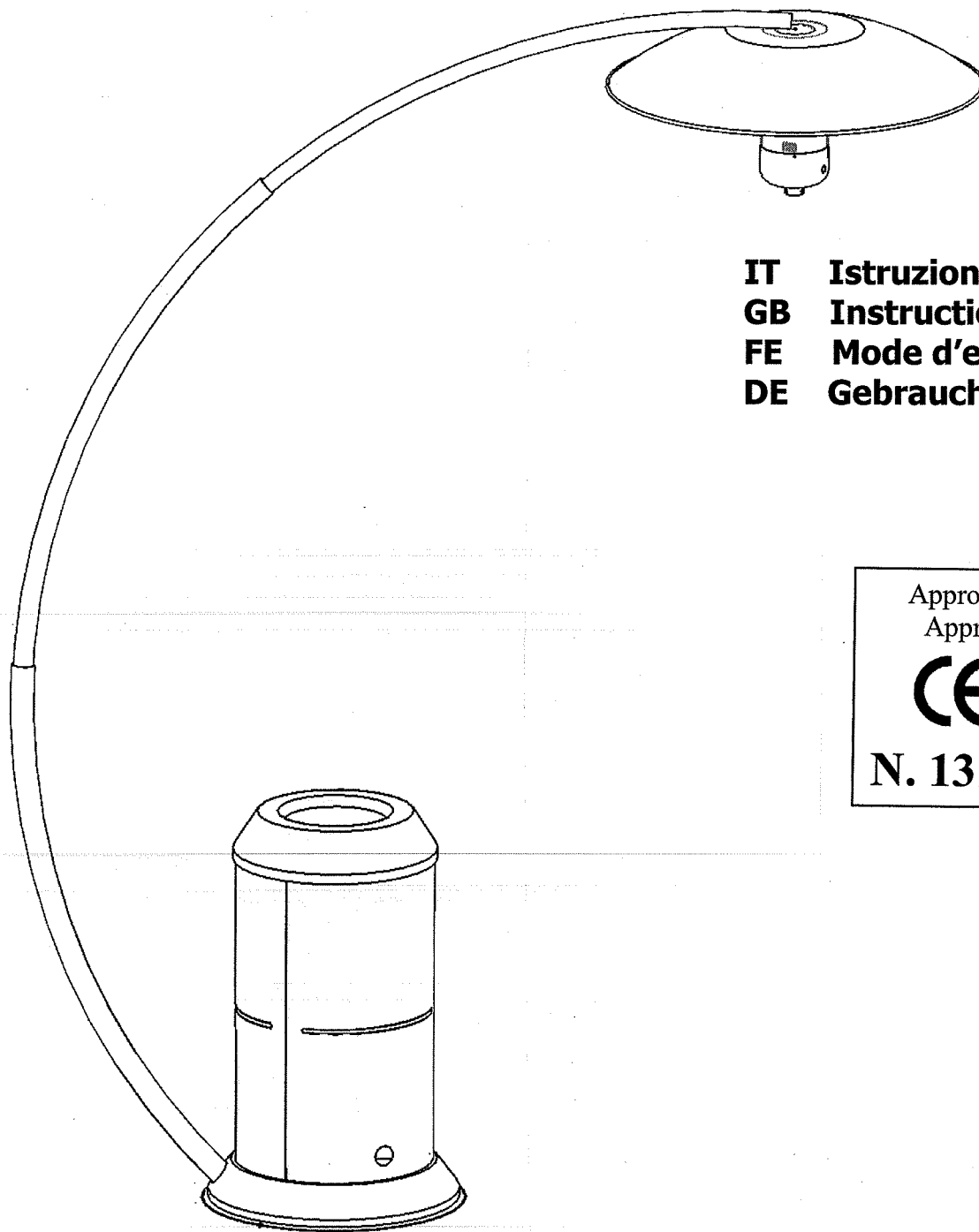











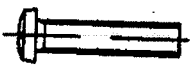
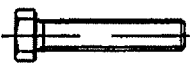
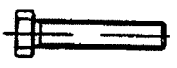

**IT Istruzioni per l'uso**  
**GB Instructions for use**  
**FE Mode d'emploi**  
**DE Gebrauchsanweisung**

Approvato – Approved  
Approuvé- Geprüft

**CE 1312**

**N. 1312BN3695**

**ELENCO VITERIA PER ASSEMBLAGGIO - LISTE DES VIS POUR L'ASSEMBLAGE  
SCREWS LIST FOR THE ASSEMBLING - LISTE DER SCHRAUBEN FUER DEN AUFBAU**

<i>Descrizione Description Description Beschreibung</i>	<i>Part. Item Pièce Artikel</i>	<i>Q.tà Q.ty Q.tè Stueck</i>	<i>Descrizione Description Description Beschreibung</i>	<i>Part. Item Pièce Artikel</i>	<i>Q.tà Q.ty Q.tè Stueck</i>
	<b>1</b>	<b>4</b>		<b>8</b>	<b>2</b>
	<b>2</b>	<b>6</b>		<b>9</b>	<b>2</b>
	<b>3</b>	<b>6</b>		<b>10</b>	<b>2</b>
	<b>4</b>	<b>1</b>		<b>11</b>	<b>1</b>
	<b>5</b>	<b>1</b>		<b>12</b>	<b>1</b>
	<b>6</b>	<b>1</b>		<b>13</b>	<b>1</b>
	<b>7</b>	<b>1</b>		<b>14</b>	<b>1</b>

**ISTRUZIONI PER IL MONTAGGIO  
ASSEMBLING INSTRUCTIONS  
INSTRUCTIONS POUR LE MONTAGE  
MONTAGEANLEITUNGEN**

- Leggere attentamente queste istruzioni prima di eseguire qualsiasi operazione.
- Read carefully these operating instructions before making any operation.
- Lire attentivement ce mode, d'emploi avant toute opération.
- Vor Inbetriebnahme unbedingt nachstehende Anleitungen durchlesen.

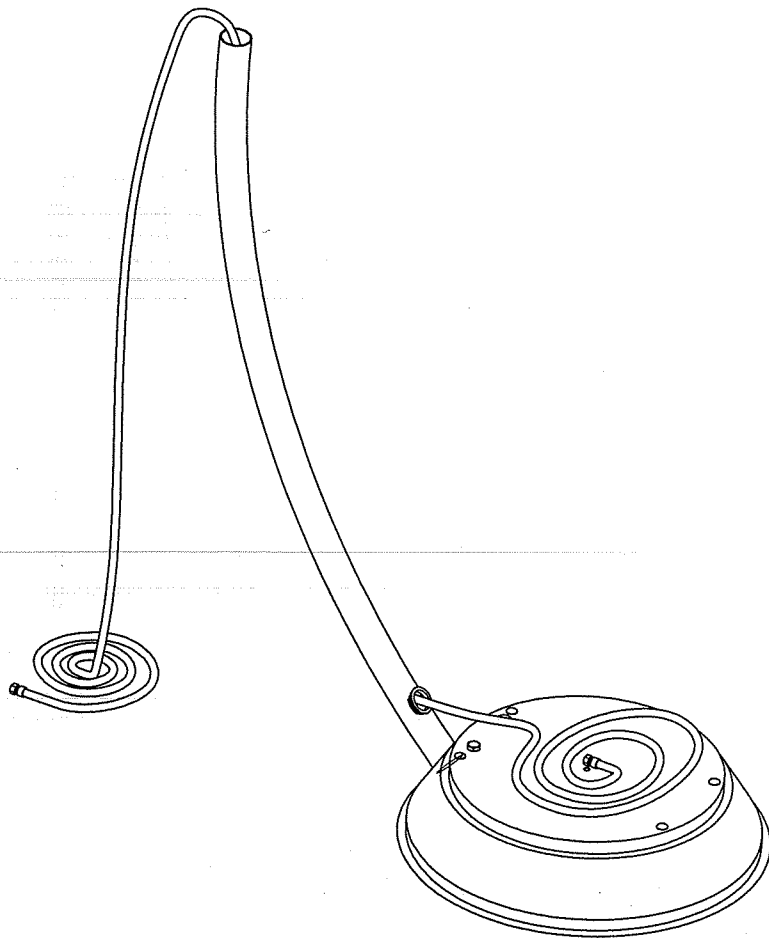
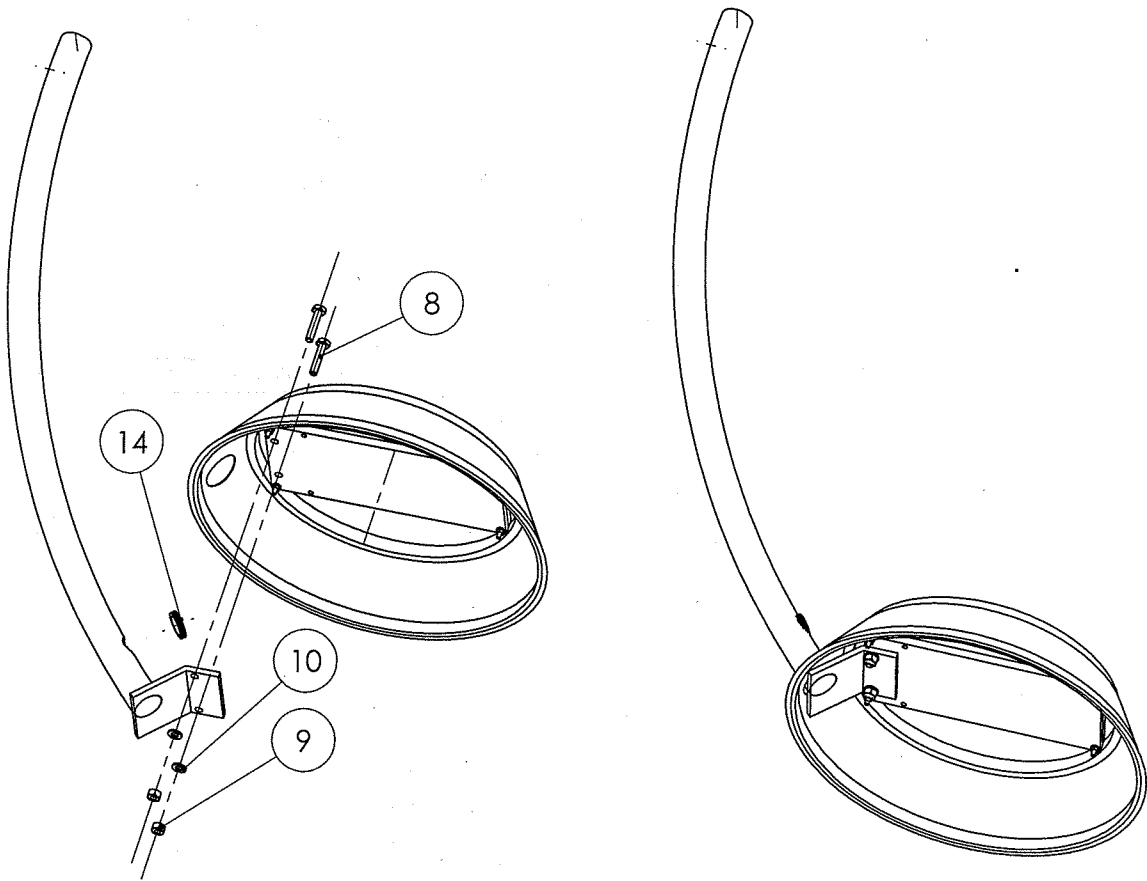

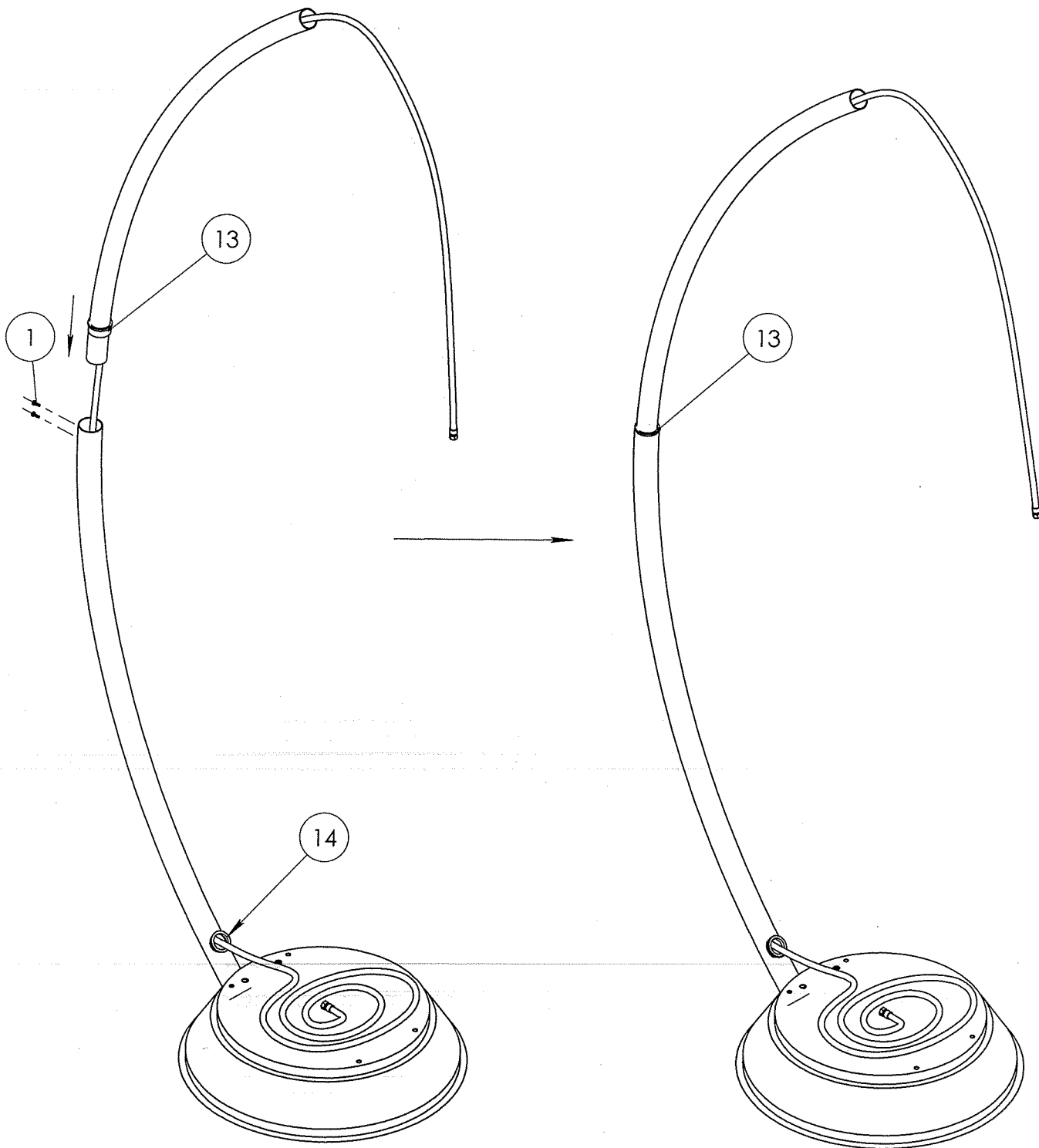

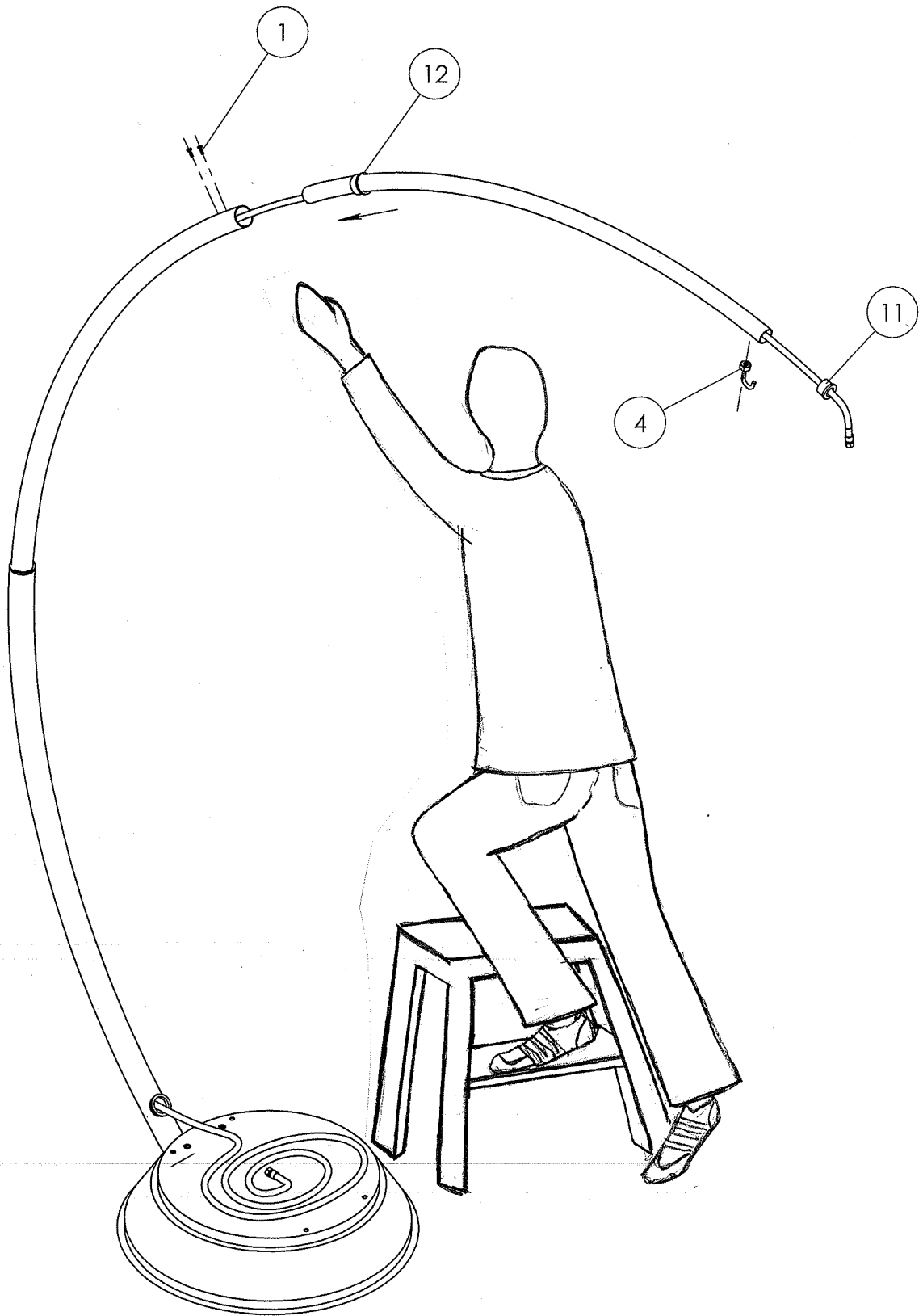

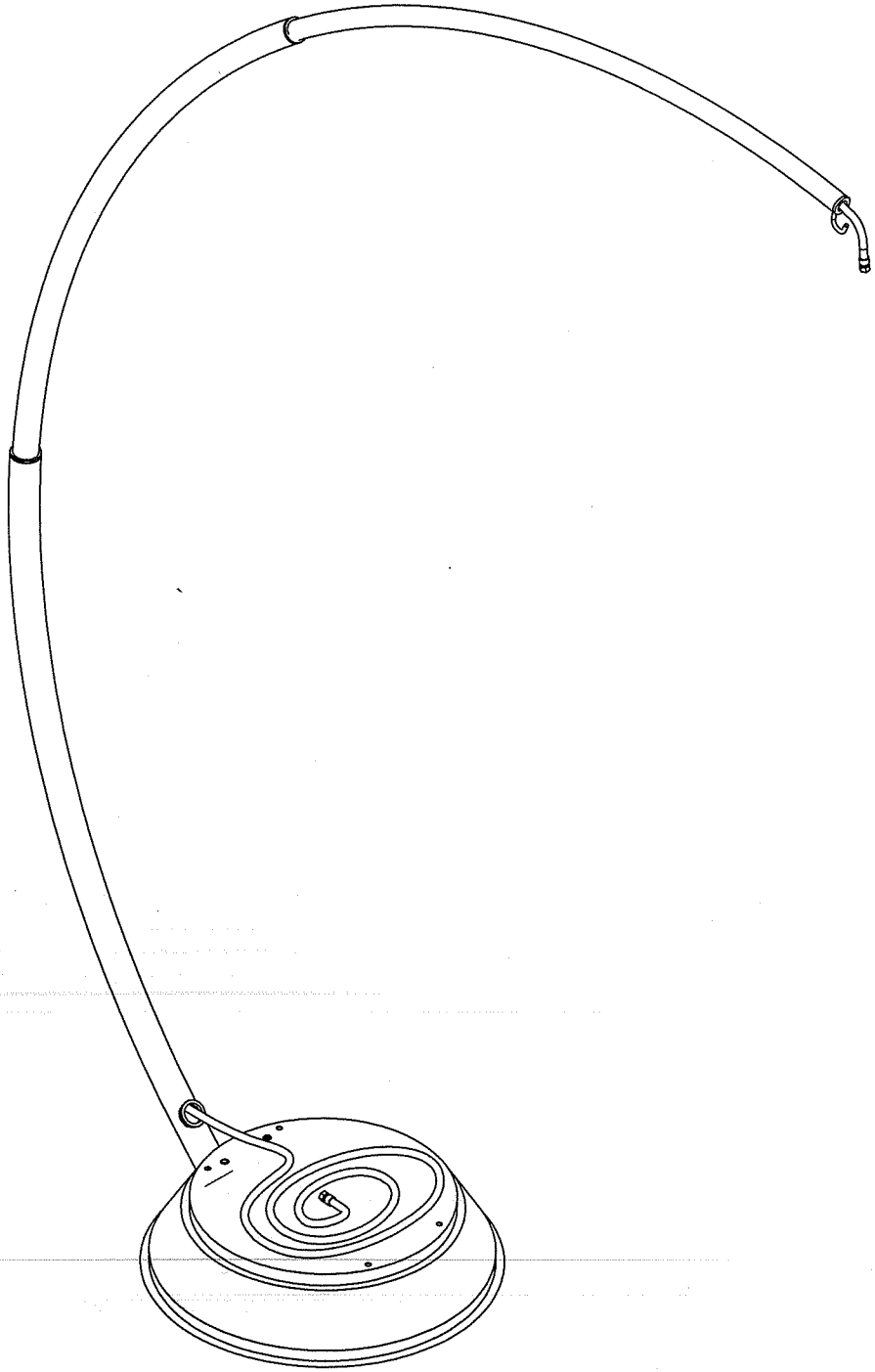

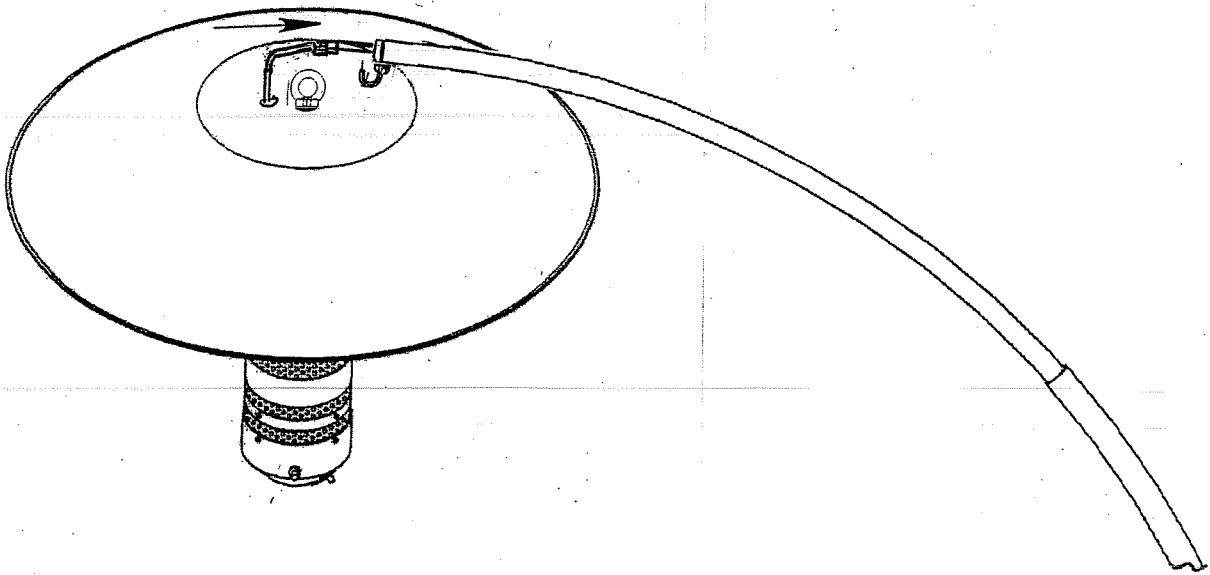
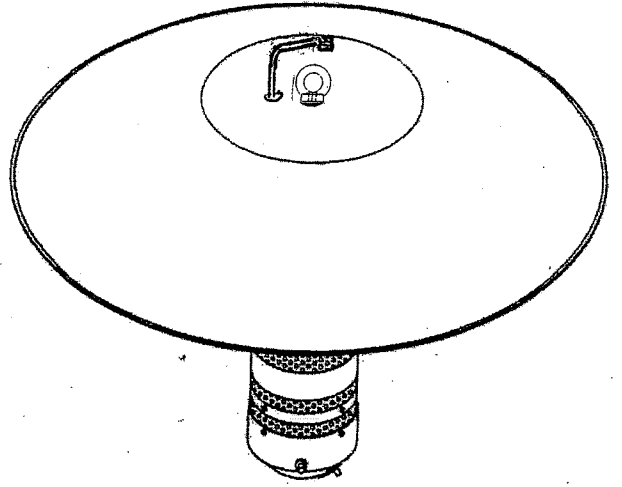
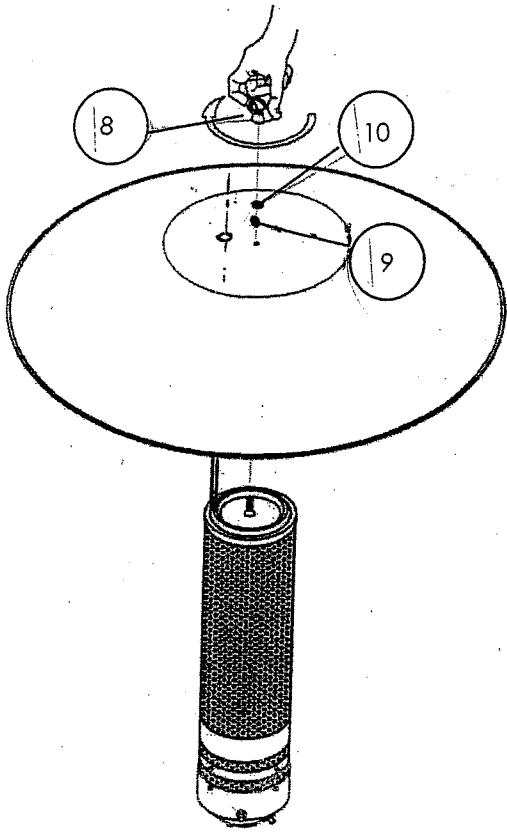

**VERIFICHE PRE-FUNZIONALI, PERIODICHE E SCHEMA ACCENSIONE  
CONTROLES PRE-FONCTIONNELS, PERIODIQUES ET PLAN D'ALLUMAGE  
PRE-FUNCTIONAL AND PERIODICAL CHECKS. IGNITION OUTLINE  
VORINBETRIEBSNAHMEKONTROLLEN, PERIODISCHE KONTROLLEN UND  
ZUENDUNGSSCHEMA**

- Mantenere premuto il pulsante per almeno 10 secondi prima di rilasciarlo.
- Keep the button depressed for at least 10 seconds before releasing it.
- Maintenir le bouton pressé pendant au moins 10 secondes avant de le relâcher.
- Den Knopf für mindestens 10 Sekunden gedrückt halten und dann loslassen.

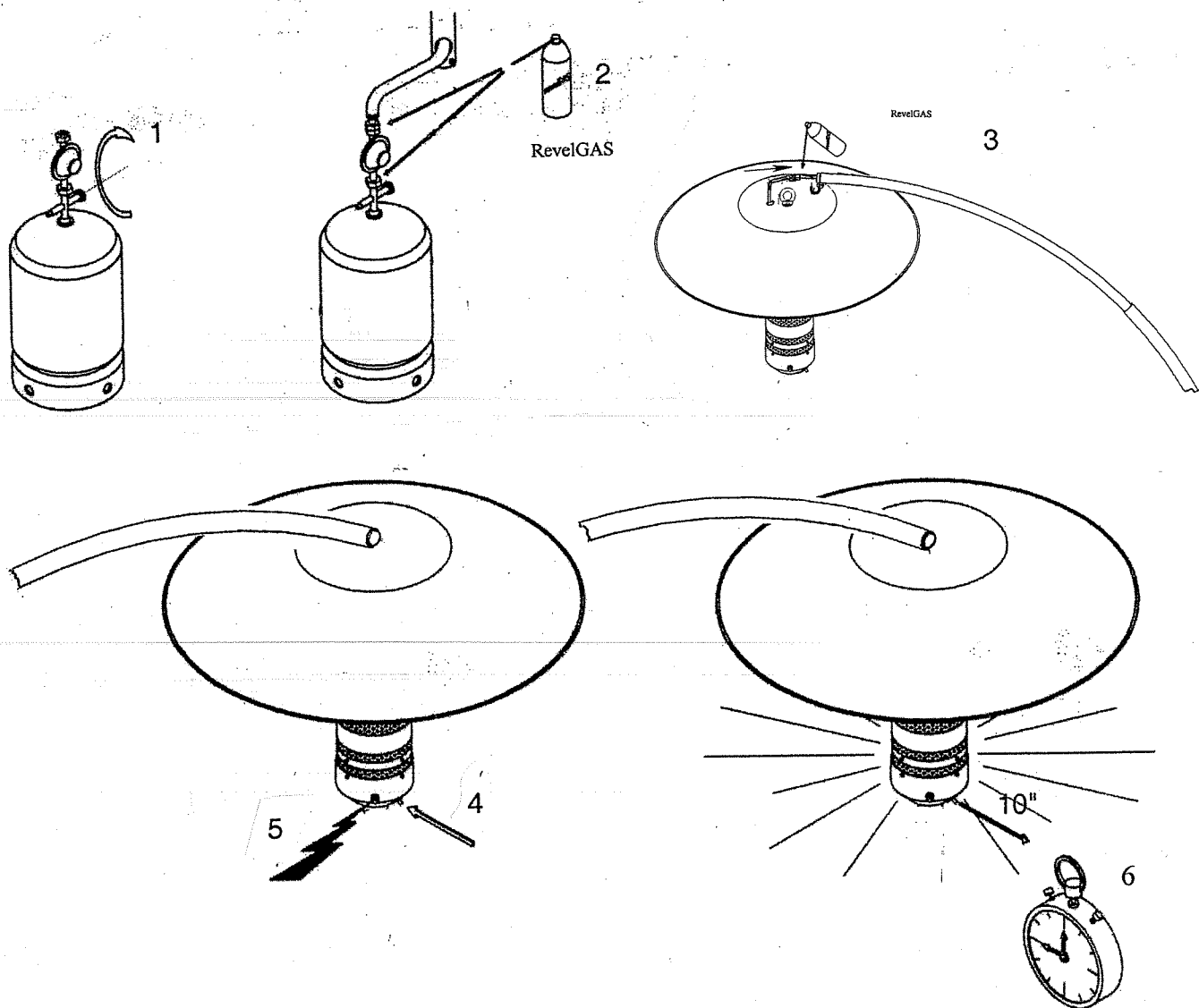

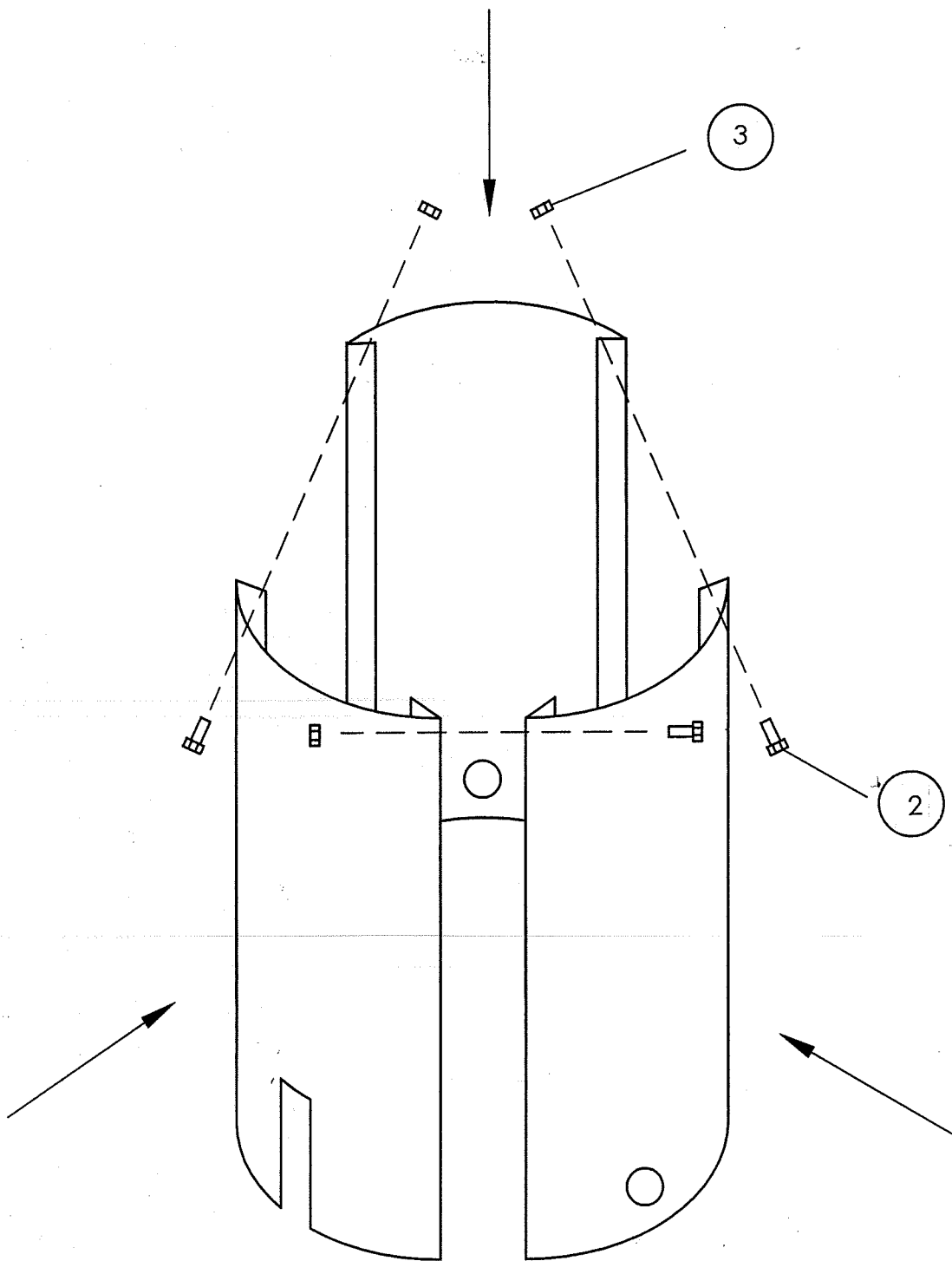

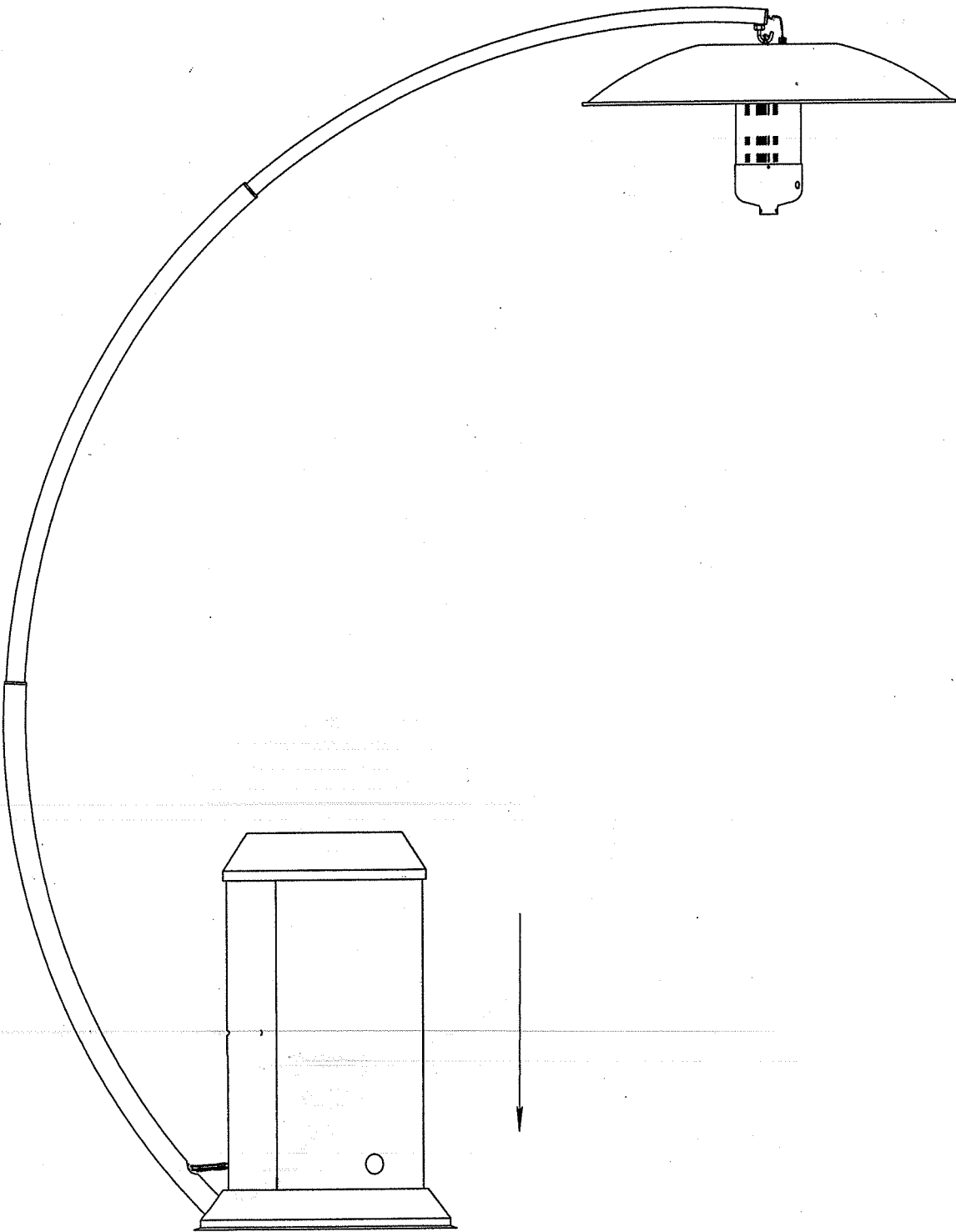

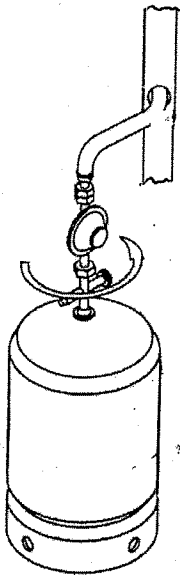

- Verificare periodicamente.
- Vérifier périodiquement.
- Check at regular intervals.
- Regelmässig warten.

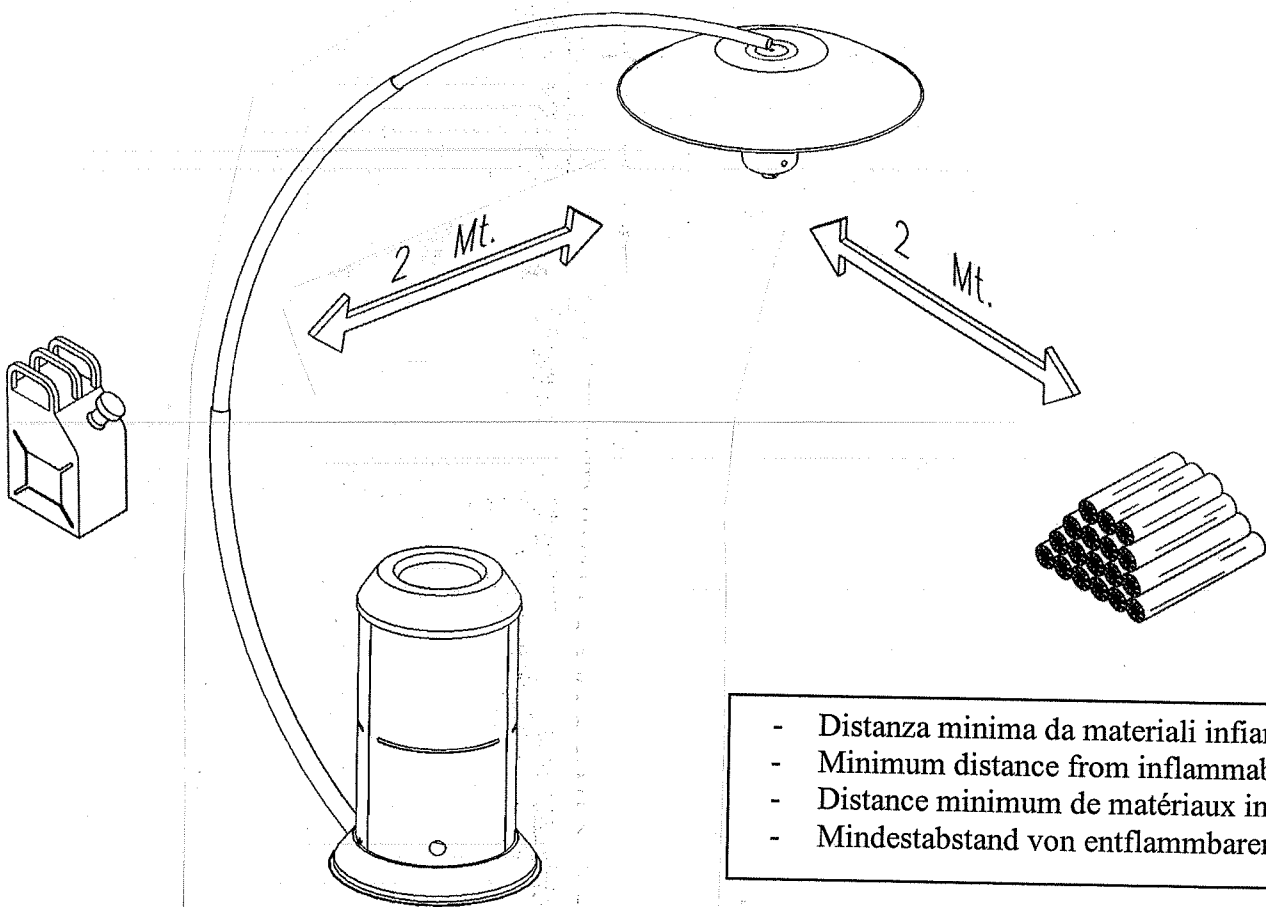
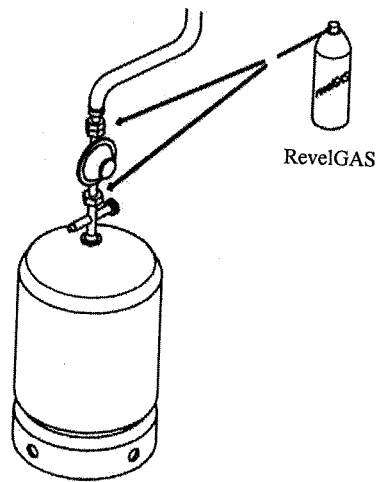

- Distanza minima da materiali infiammabili.
- Minimum distance from inflammable materials.
- Distance minimum de matériaux inflammanbles.
- Mindestabstand von entflammbarem Material.

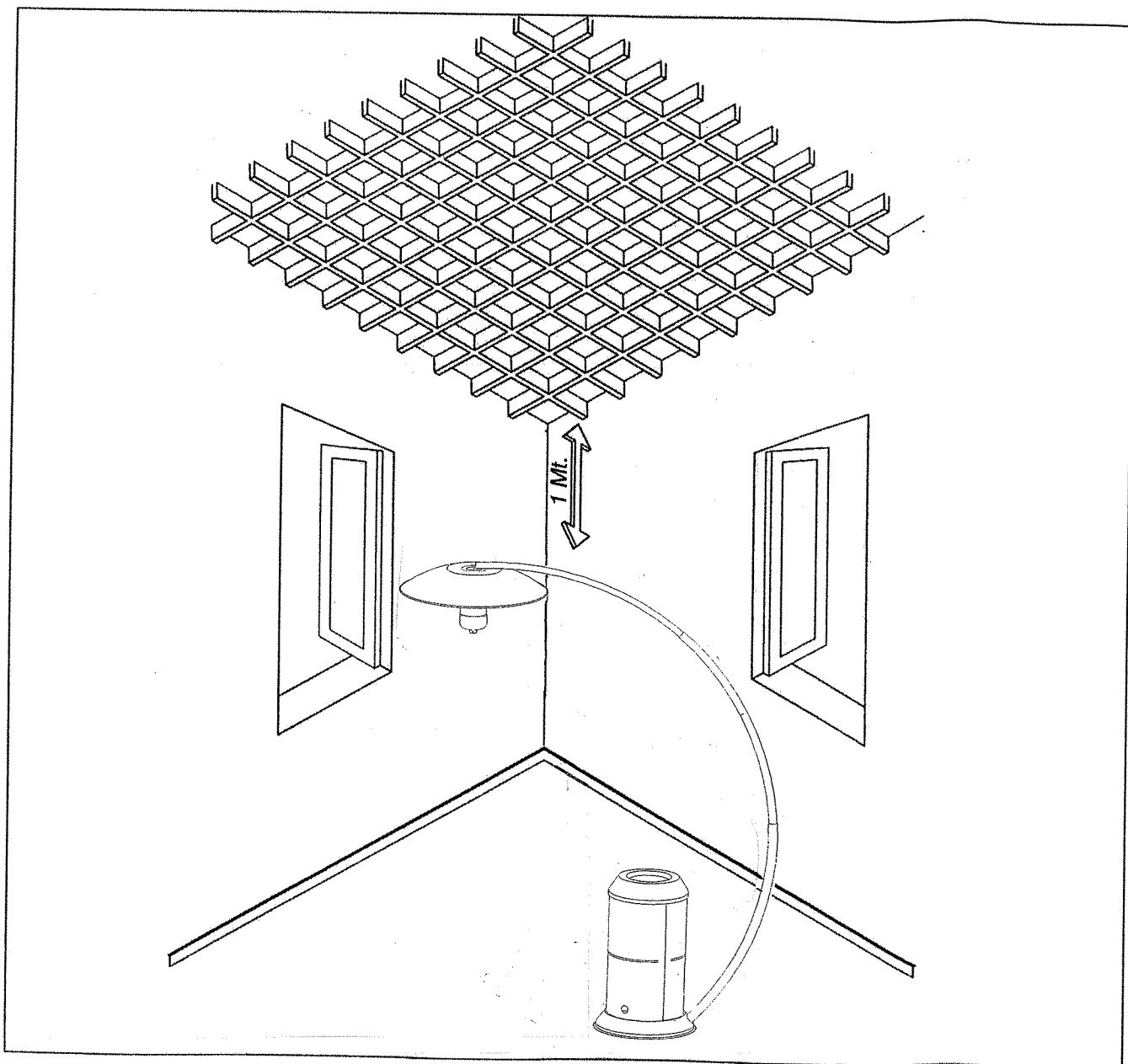

- Distanza minima da coperture infiammabili.
- Minimum distance from inflammable covers.
- Distance minimum de couvertures inflammables.
- Mindestabstand von entflammbaren Abdeckungen.

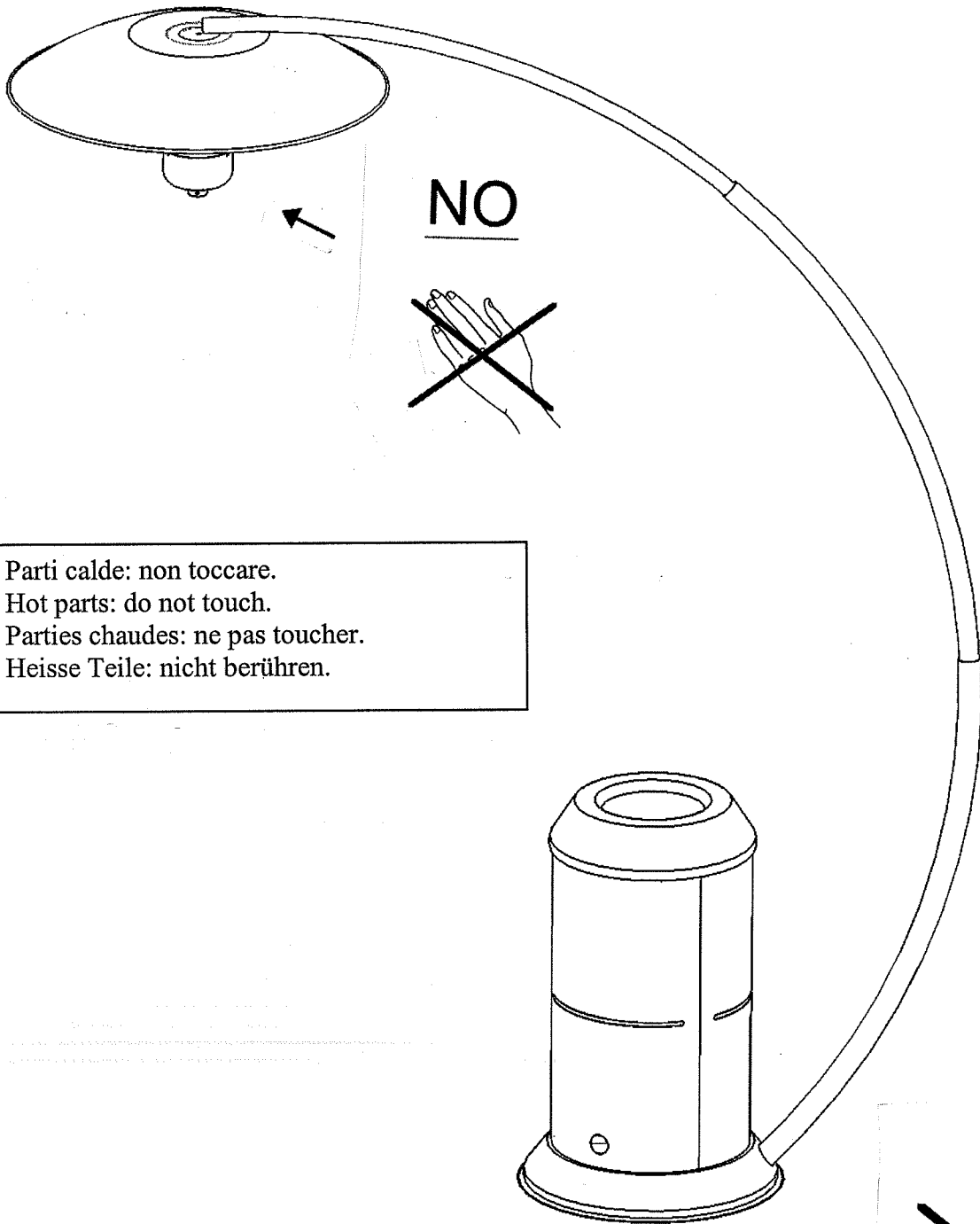

- Parti calde: non toccare.
- Hot parts: do not touch.
- Parties chaudes: ne pas toucher.
- Heisse Teile: nicht berühren.

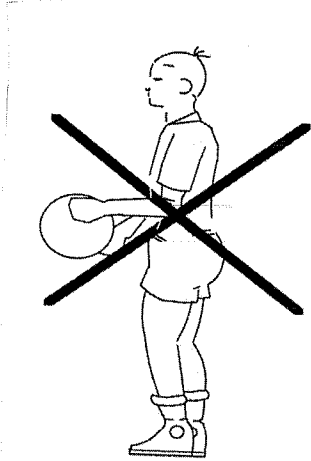

- Tenere lontano dalla portata dei bambini.
- Keep away from children.
- Maintenir hors de la portée des enfants.
- Halten Sie das Gerät fern von Kindern.

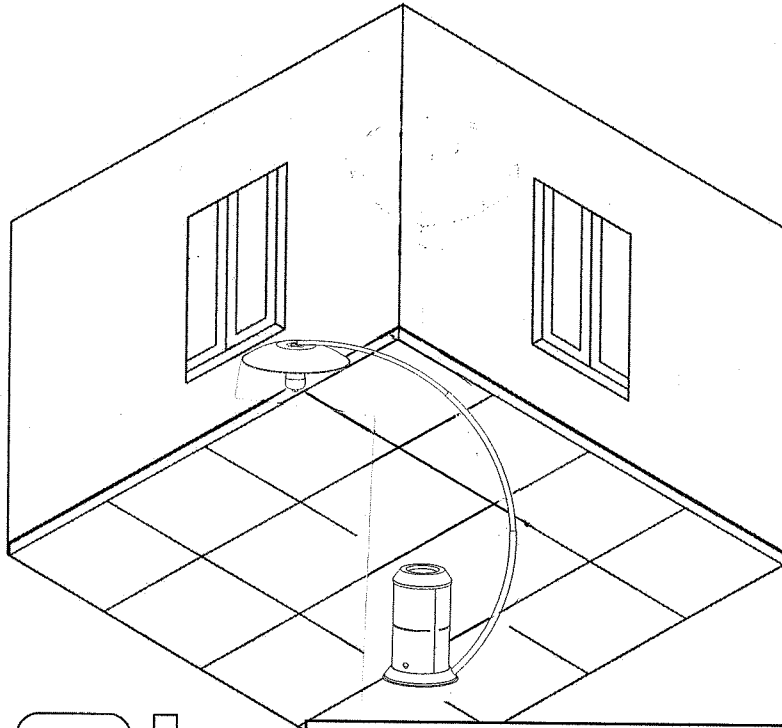

# NO!

- Non utilizzare al chiuso.
- Do not use indoors.
- Ne pas utiliser dans un endroit fermé.
- Verwenden Sie das Gerät nicht in geschlossenen Räumen.

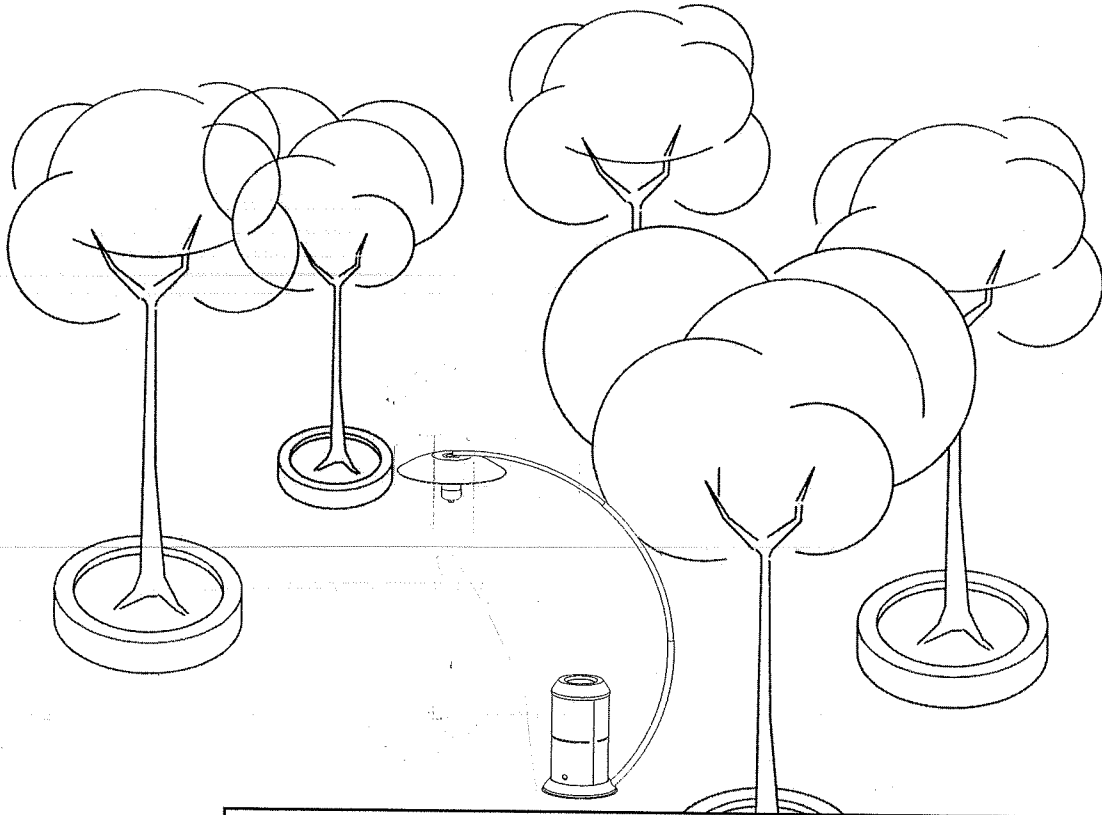

# OK!

- Utilizzare all'aperto o in zone ben aerate.
- Use the appliance outdoors or in well ventilated areas.
- Utiliser en plein air ou dans des endroits bien ventilés.
- Verwenden Sie da Gerät im Freien oder in gut durchlüfteten Räumen.

- In caso di vento appesantire la base con pesi esterni oppure ancorare al suolo.
- In case of wind weigh down the base with with external weights or fix it to the floor.
- En cas de vent alourdir la base avec des poids externes ou la fixer au sol.
- Bei Wind beschweren Sie die Basis mit Gewichten oder verankern Sie diese am Boden.

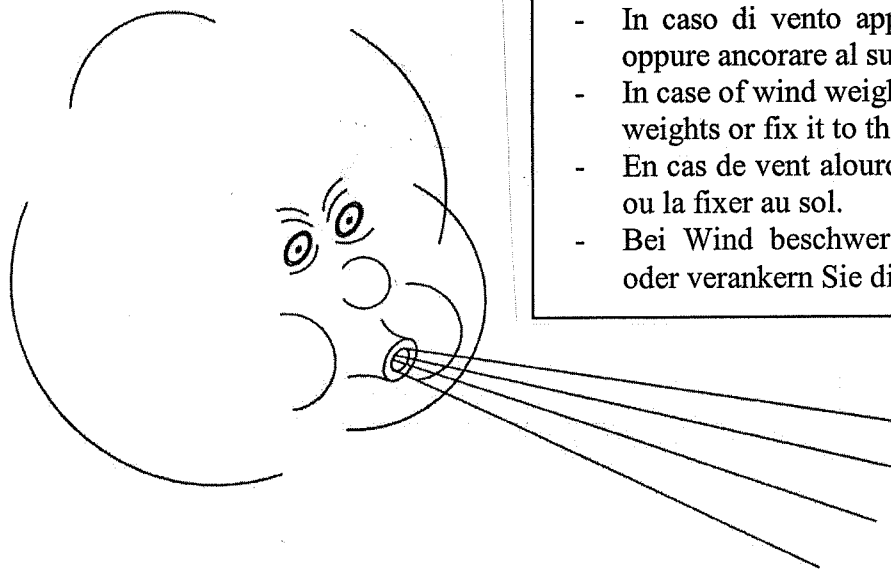

NO!

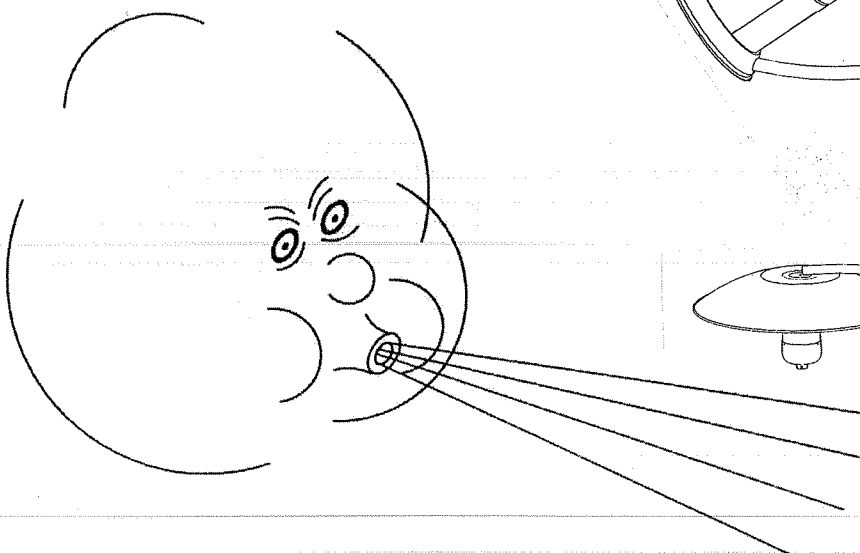
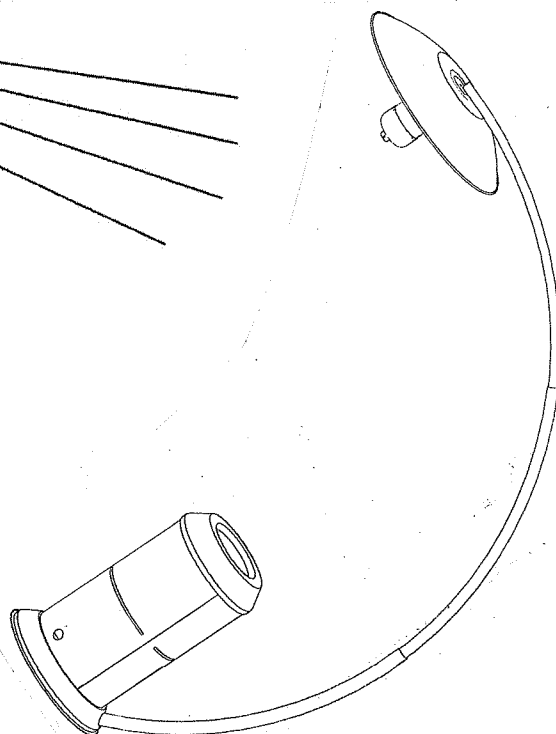

OK!

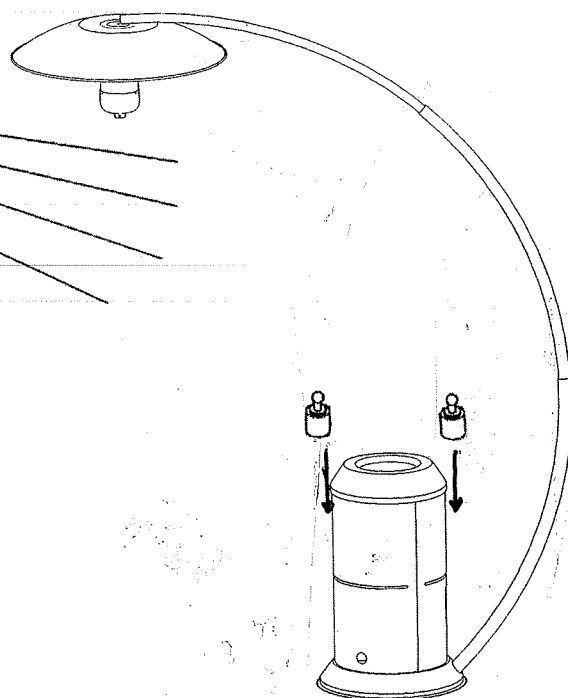

- L'apparecchio può essere utilizzato con bombole di capacità massima 13 kg.
- The appliance can be used with gas cylinders having a maximum capacity of 13 kg.
- L'appareil peut être utilisé avec des bouteilles de capacité maximum 13 kg.
- Das Geraet kann mit Gasflasche mit einer Maximalfuellmenge von 13 kg verwendet werden.
- L'apparecchio deve essere utilizzato con un tubo flessibile secondo le norme vigenti di lunghezza 1,5 mt.
- The appliance must be used with a 1,5 mt. flexible hose according to the regulations in force.
- L'appareil doit fonctionner avec un tuyau flexible de 1,5 de long selon les lois en vigueur.
- Das Geraet muss mit einem flexiblen Schlauch gemaess der geltenden Gsetzesnormen mit einer Länge von 1,5 mt verwendet werden.
- Sostituire la bombola in un luogo ben aerato, lontano da fiamme e da fonti di calore.
- Replace the gas bottle in a well ventilated area, away from flames and heat sources.
- Remplacer la bouteille de gaz dans un endroit bien aéré et loin de toute flamme ou source de chaleur.
- Tauschen Sie Gasflaschen nur in gut belüfteten Räumen und fern von Feuer- und Hitzequellen aus.
- Si consiglia di fare controlli frequenti e, in caso di necessità, provvedere alla sostituzione del tubo flessibile. Assicurarsi della presenza e del buono stato della guarnizione del regolatore. E' necessario l'utilizzo di un regolatore di pressione da 1,5 kg/h (max 30 o 37 mbar secondo necessità);
- We suggest you to make frequent checks and if it is necessary, to replace the flexible hose. Check that the regulator seal is fitted and that it is in good conditions. You have to use a pressure reducer gauged on 1,5 kg/h (max 30 or 37 mbar).
- Nous vous recommandons d'effectuer de contrôles fréquents et s'il est nécessaire, de remplacer le tuyau flexible. S'assurer de la présence et du bon état du joint du détendeur. Il faut utiliser un détendeur de pression à sécurité NF 1500 g/h – 37 mbar pour le propane et 1300 g/h – 28 mbar pour le butane.
- Es empfiehlt sich das Gerät regelmässig zu überprüfen und, wenn notwendig, den flexiblen Schlauch zu ersetzen. Kontrollieren Sie auch, dass die Dichtung des Reglers vorhanden und in gutem Zustand ist. Es ist nötig einen Druckregler mit Druck 1,5 kg/h (max. Betriebsdruck 50 mbar) zu verwenden.
- Si raccomanda di spegnere sempre completamente la vostra apparecchiatura al termine dell'impiego chiudendo il rubinetto della bombola del gas.
- Always turn off completely your appliance each time you use it and at the same time close the valve of the gas cylinder.
- Nous vous recommandons d'éteindre toujours complètement votre appareil à la fin de chaque emploi et dans le même temps de fermer le robinet de la bouteille de gaz.
- Es wird empfohlen, nach jedem Einsatz Ihr Geraet auszuschalten und den Gashahn der Flasche zu schliessen.
- Non spostare l'apparecchio durante il funzionamento.
- Do not move the appliance when in operation.
- Ne pas déplacer l'appareil pendant le fonctionnement.
- Verschieben Sie das Gerät nicht während des Gebrauchs.
- Non utilizzare in alimentazione butano quando la temperatura è inferiore a 5 °C.
- Do not use a butane supply when the temperature is below 5 °C.
- Ne pas utiliser en alimentation butane lorsque la température est inférieure à 5 °C.
- Nicht mit Butanzufuhr verwenden, wenn die Temperatur unter 5 °C beträgt.

Ø Iniettore Injector Injecteur Injektor	Tipo di gas Type of gas Type de gaz Gasart	Potenza Power Puissance Nennwärmebelastung		Consumo Consumption Consommation Anschlusswert	
30 mbar Ø 1,15 50 mbar Ø 1,15+ étrangleur 1,20	Propano-Butano Propane-Butane Propane-Butane Propan-Butan	kW 5,5		380 g/h	
Paese di destinazione Destination country Pays de destination Bestimmungsland	Categoria Category Kategorie Categorie	Pressione esercizio Operating pressure Pression de service Betriebsdruck	Dimensioni Dimensions Dimensions Dimension mm.	Peso Weight Poids Gewicht kg.	
DE-AT	I3 B/P	50 mbar	h 2200 Ø 740	12	
BE-GR-IT-PT-ES-GB-IE-CH-FR-LU	I3+	28-30/37 mbar			
NO-NL-DK-SE-FI	I3 B/P	30 mbar			